



May 2024

CONTRACT FINANCING

Factors That Influence the Use of Financing Methods and DOD's Progress on Proposed Actions

Why GAO Did This Study

In fiscal years 2022 and 2023, DOD provided over \$100 billion in contract financing to contractors to acquire weapon systems and satellites, among other products. In April 2023, DOD completed a study on the effect of its contract financing and profit policies on the defense industry. This study was in response to a June 2019 GAO report, which noted that DOD had last assessed its contract financing policies in 1985. The 2023 study resulted in several proposed actions for DOD.

A Joint Explanatory Statement included a provision for GAO to review the results of DOD's Contract Finance Study. This report describes (1) how contracting officers decide to use progress or performance-based payments and the extent to which DOD used these payments from fiscal years 2013 to 2023; and (2) the extent to which DOD implemented the proposed actions of its study.

GAO reviewed the Federal Acquisition Regulation, the Defense Federal Acquisition Regulation Supplement, and DOD guidance to understand when and how progress and performance-based payments can be used. GAO also reviewed fiscal years 2013 to 2023 data on DOD's use of these payments and DOD's April 2023 Contract Finance report; and interviewed DOD contract policy officials and contracting officers from the Army, Navy, Air Force and Defense Logistics Agency. GAO selected contracting officers based on the type of contract financing used in high value contracts. GAO also interviewed industry representatives to obtain their views on the DOD finance report.

View [GAO-24-106850](#). For more information, contact Mona Sehgal at (202) 512-4841 or SehgalM@gao.gov.

CONTRACT FINANCING

Factors That Influence the Use of Financing Methods and DOD's Progress on Proposed Actions

What GAO Found

The Department of Defense (DOD) has long recognized that weapon systems—such as aircraft, missiles, and satellites—are capital intensive and take a long time to produce. One way DOD helps contractors manage these expenses is through contract financing.

One form of financing is progress payments, which are paid to contractors as a percentage of costs incurred by the contractor. Another form is performance-based payments, which are made to contractors upon completion of milestones, such as the delivery of a part.

In the last decade, DOD provided more progress payments than performance-based payments to contractors. In fiscal year 2023, DOD provided approximately \$28 billion in progress payments and \$22 billion in performance-based payments. Contracting officers stated that they consider several factors when deciding between progress or performance-based payments, as shown below.

Factors Department of Defense (DOD) Contracting Officers Consider When Deciding on the Use of Progress or Performance-Based Payments

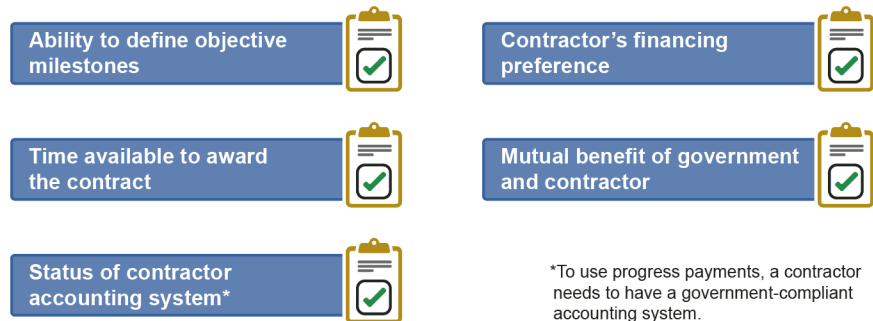

Source: GAO interviews with selected DOD contracting officers. | [GAO-24-106850](#)

Based on its April 2023 Contract Finance study, DOD proposed 16 actions it could take to help expand the defense industrial base. As of January 2024, DOD had taken steps toward implementing the majority of the proposed actions. DOD estimates that most of these actions will take 1 to 3 years to complete because they are proposed to be regulatory changes. Several of these proposed actions are intended to help subcontractors and small businesses, and include:

- Improving the ability of subcontractors to contact the contracting officer when they do not receive payments from prime contractors, and
- Modifying various regulations, as needed, to improve timely payments to subcontractors, including small businesses.

One near-term proposed action is the use of a model to help educate contracting officers on the importance of cash-flow to contractors. The goal of the model is to help contracting officers negotiate a better deal for the government compared to a contractor's proposal. DOD plans to introduce the new cash-flow model sometime in 2024.

Contents

Letter		1
	Background	3
	Several Factors Influence Financing Option Used, with Progress Payments Outpacing Performance-Based Payments	8
	DOD's Proposed Actions Are in Various Stages of Completion	13
	Agency Comments	19
Appendix I	Comments from the Department of Defense	21
Appendix II	GAO Contact and Staff Acknowledgments	22
Tables		
	Table 1: Key Differences between Progress and Performance-Based Payments in Department of Defense (DOD) Contracts	5
	Table 2: Time Frames and Status of DOD's Proposed Contract Finance Actions, as of January 2024	13
Figures		
	Figure 1: Differences in How Progress Payments and Performance-Based Payments May Be Used on a Contract	6
	Figure 2: Department of Defense (DOD) Progress and Performance-based Payments, Fiscal Years (FY) 2013-2023	11
	Figure 3: Comparison of the Department of Defense's (DOD) Progress and Performance-based Payments by Commodity, Fiscal Year 2023	12

Abbreviations

DCMA	Defense Contract Management Agency
DFARS	Defense Federal Acquisition Regulation Supplement
DOD	Department of Defense
DPC	Defense Pricing and Contracting
FAR	Federal Acquisition Regulation
FY	fiscal year

This is a work of the U.S. government and is not subject to copyright protection in the United States. The published product may be reproduced and distributed in its entirety without further permission from GAO. However, because this work may contain copyrighted images or other material, permission from the copyright holder may be necessary if you wish to reproduce this material separately.



May 22, 2024

Congressional Committees

In fiscal years 2022 and 2023, the Department of Defense (DOD) provided over \$100 billion in contract financing to contractors to acquire weapon systems, such as aircraft, missiles, and satellites. DOD has long recognized that items like weapon systems are capital intensive and take a long time to produce. DOD uses contract financing to help stabilize contractors' cash flow and reduce their need to borrow from commercial sources or use their own funds to cover the cost to produce these capital-intensive systems. The government's financing of contracts, which often takes the form of progress or performance-based payments, can also result in lower prices or other contractual benefits for the government, such as quicker deliveries.

In April 2023, DOD completed an assessment of the effect that its contract financing and profit policies have on the defense industry.¹ This study was in response to our June 2019 report, which noted that DOD had last assessed its contract financing policies in 1985.² In that report, we recommended that DOD conduct a comprehensive assessment of the effect that its contract financing and profit policies have on the defense industry. The report noted that overall, the defense industry is financially healthy. However, it also noted that prime contractors receive better cash flow from contract financing policies than subcontractors do. DOD reported that improvements in this area could help attract new entrants to the defense industrial base. The April 2023 contract finance study proposed several actions that DOD could take that might help in this area.

The Joint Explanatory Statement accompanying the National Defense Authorization Act for Fiscal Year 2023 asked us to assess the results of the study.³ This report describes (1) how contracting officers decide on the use progress or performance-based payments and the extent to

¹Department of Defense, Office of the Under Secretary of Defense for Acquisition and Sustainment, Defense Pricing and Contracting, *Contract Finance Study Report* (April 2023).

²GAO, *Contract Financing: DOD Should Comprehensively Assess How Its Policies Affect the Defense Industry*, [GAO-19-406](#) (Washington, D.C.: June 27, 2019).

³168 Cong. Rec. H9425, H9473 (Dec. 8, 2022) (Joint explanatory statement accompanying the James M. Inhofe National Defense Authorization Act for Fiscal Year 2023).

which DOD used these payments from fiscal years 2013 to 2023; and (2) the extent to which DOD implemented the proposed actions of its April 2023 study.⁴

To determine how contracting officers decide between providing progress or performance-based payments, we reviewed the Federal Acquisition Regulation (FAR), Defense Federal Acquisition Regulation Supplement (DFARS), and DOD guidance to understand when these payments can be used. Additionally, we used data from the Federal Procurement Data System to pick a nongeneralizable sample of contracting officers to interview. We selected contracting officers from the Army, Navy, Air Force, and Defense Logistics Agency because these components have the most contracting activity within DOD. We further analyzed the data to identify the contracting offices within the selected components with the most obligations on contracts that used either progress or performance-based payments from fiscal years 2021 and 2022, the most recent data available at the time of our review. We then selected and interviewed 36 contracting officers associated with contracts that used progress or performance-based payments. Though not generalizable to all contracts using progress or performance-based payments, information from these interviews provided insights into the factors that contracting officers may consider when determining which type of financing to offer. We excluded shipbuilding and construction contracts since these DOD contracts typically do not use performance-based payments and we wanted to interview contracting officers who had a choice to use either form of financing. We reviewed contract documents where appropriate to better understand how performance-based payments were used. We also interviewed senior level contracting officials, such as directors or those in charge of policy decisions, to discuss their policies and practices regarding contract financing.

To determine DOD's use of progress and performance-based payments from fiscal years 2013-2023, we analyzed data from DOD's Mechanization of Contract Administration Services database, the system of record for processing contract financing payments for Defense

⁴Throughout this report when we say "progress payments" we are referring to progress payments based on costs incurred and not on progress payments based on percentage or stage of completion. This latter form of progress payments is typically used on shipbuilding and construction contracts.

Contract Management Agency (DCMA)-administered contracts.⁵ We used these data to determine the amount of contract financing payments DOD made, and the types of commodities for which financing was used. The numbers were adjusted for inflation, using the fiscal year 2023 Gross Domestic Product Price Index. We reviewed documentation on the database and interviewed knowledgeable officials to determine the reliability of the data. We found the data to be sufficiently reliable to report the amount paid using these specific contract financing options during this time frame and the specific commodities for which financing was used.

To determine the extent to which DOD has plans to implement the proposed actions of its 2023 study, we reviewed the study and interviewed officials in the Defense Pricing and Contracting (DPC) office, which was responsible for the study. We also interviewed officials in the Offices of Small Business programs at the three military departments to discuss how the DOD contract finance study's proposed actions could affect small businesses. Finally, we interviewed representatives from the Aerospace Industries Association, National Defense Industrial Association, and the Professional Services Council to discuss their perspectives on DOD's proposed actions.

We conducted this performance audit from May 2023 to May 2024 in accordance with generally accepted government auditing standards. Those standards require that we plan and perform the audit to obtain sufficient, appropriate evidence to provide a reasonable basis for our findings and conclusions based on our audit objectives. We believe that the evidence obtained provides a reasonable basis for our findings and conclusions based on our audit objectives.

Background

For several decades, DOD has recognized the benefit of providing contract financing to its contractors for capital intensive weapon systems. Contract financing helps defense contractors manage expenses on such projects for things like material, labor, and overhead. DOD may finance contractor expenses through various types of financing arrangements. Two types of financing—progress payments and performance-based

⁵Mechanization of Contract Administration Services is an integrated contract administration and payment system. It is designed to provide the Defense Contract Management Agency and the Defense Finance and Accounting Service with electronic information necessary to accomplish their mission of contract and payment administration.

payments—can only be used on noncommercial firm-fixed-price contracts.⁶

Progress and Performance-Based Payments

- **Progress payments based on cost** are determined as a percentage of the costs incurred by the contractor as work progresses. Currently, DOD provides a progress payment rate of 80 percent of incurred costs to large businesses and 95 percent for small businesses. Typically, progress payments are made to the contractor not more than once per month.
- **Performance-based payments** are typically made to contractors upon completion of certain milestones, such as delivery of a major subcontracted component or successful completion of an evaluation. These milestones must be negotiated and agreed upon by DOD and the contractor, and payments are made up to 90 percent of a contract's price, for large or small businesses.

According to the FAR, performance-based payments are the preferred method of financing. This financing can be used when the contracting officer finds these payments to be practical and the contractor agrees to their use.⁷ For large businesses, both progress and performance-based payments may be used on fixed-price contracts over \$3 million. For small businesses, these forms of financing may be used on contracts over the simplified acquisition threshold.⁸ Further, regulations state that these two types of financing may not be used on the same contract. However, the circumstances and requirements associated with using progress and performance-based payments differ. Table 1 summarizes some of these differences.

⁶Performance-based payments may also be used on fixed-price orders or line items. FAR 32.1003. Other types of contract financing include progress payments based on percentage or stage of completion, advance payments, and unusual forms of contract financing. Advance payments are generally payments made before work on a contract starts. These latter two financing approaches are lower in order of preference in the FAR. See FAR § 32.106. The government may also provide financing on commercial contracts under certain circumstance through interim payments or advance payments, but not progress or performance-based payments. Firm-fixed-price contracts provide for a firm price even if the actual total cost of the product or service falls short of or exceeds the contract price; fixed-price contracts can also include provisions for price adjustment.

⁷FAR 32.1001(a).

⁸The simplified acquisition threshold is generally \$250,000. See exceptions in FAR 2.101.

Table 1: Key Differences between Progress and Performance-Based Payments in Department of Defense (DOD) Contracts

	Progress payments	Performance-based payments
Total financing payment amount	Large business may receive up to 80 percent of incurred costs on contracts. Small business may receive up to 95 percent of incurred costs.	Total payments cannot exceed 90 percent of the estimated contract price. Payments may be based on negotiated value of work completed between milestones rather than the costs of performing the milestone task.
Contractor accounting system requirements	The contractor must have a government-assessed and compliant accounting system.	There are no accounting system requirements associated with performance-based contracts but the contractor's financial statements should be in compliance with Generally Accepted Accounting Principles. ^a
Pre-award analysis and negotiation	No analysis or negotiation is required. Contract clause allowing for progress payments must be included in contract.	According to DOD, analysis and negotiation of a performance-based payments schedule can take months as each event, criteria, and value must be agreed upon.
Post-award analysis and reviews	According to DOD, significant oversight is required by the government in the form of periodic post-payment reviews, including technical surveillance and to ensure costs incurred reconcile with the requested payment.	According to DOD, moderate government oversight is needed to validate completion of milestone events for each performance-based payment.

Source: Federal Acquisition Regulation and Defense Pricing and Contracting training materials. | GAO-24-106850

^aGenerally Accepted Accounting Principles are a set of U.S. accounting standards, conventions, and rules focused on measuring companies' commercial financial performance and are meant to establish and improve financial accounting and reporting.

DOD's guidance for performance-based payments states that certain procurements lend themselves to performance-based payments more readily than others. For instance, programs with stable and mature production lines are better suited for performance-based payments because these contracts have well-defined events and historical pricing data are available. In contrast, progress payments may be applied more readily in contracts where it is more difficult to identify measurable milestone events. Figure 1 shows a notional example of progress and performance-based payments for a weapon system program, illustrating the differences in the timing of payments and describing examples of milestone events the contractor must successfully complete to receive payment.

Figure 1: Differences in How Progress Payments and Performance-Based Payments May Be Used on a Contract

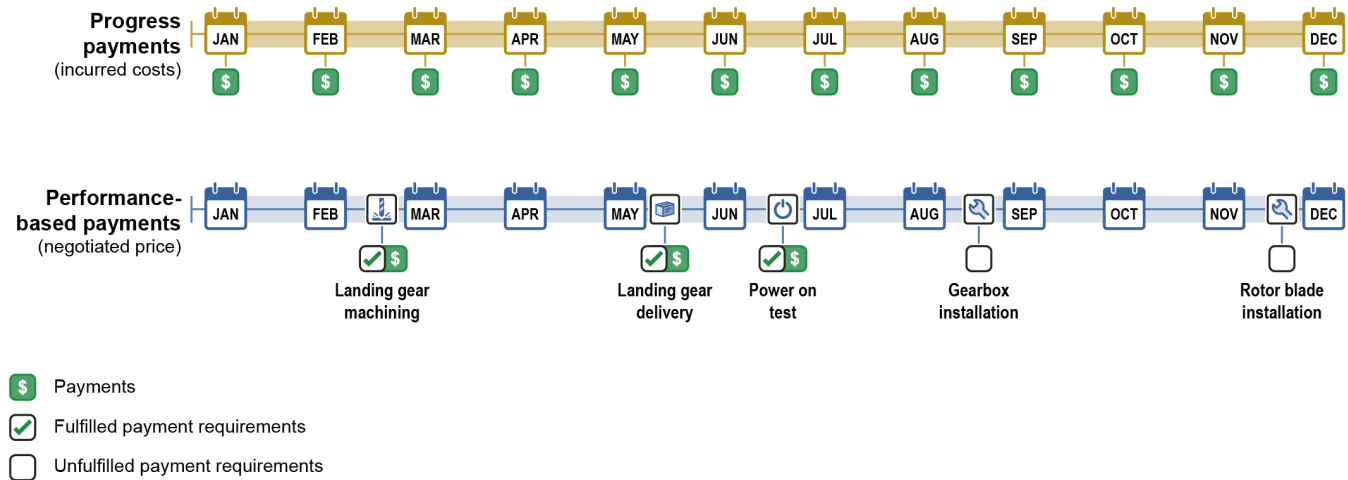

Source: GAO analysis of Department of Defense (DOD) data. | GAO-24-106850

DOD Roles in Contract Financing

Several offices and agencies within DOD have a role in managing contract financing, including:

- DPC**—which reports to the Office of the Under Secretary of Defense for Acquisition and Sustainment—is responsible for all pricing, contracting, and procurement policy matters across DOD. This office formulates and oversees DOD-wide pricing policies and strategies supporting the procurement of major defense programs, including programs that use progress and performance-based payments. Further, it conducts peer reviews of high-value noncompetitive contracts. These reviews evaluate, among other things, programs’ use of contract financing.
- DCMA** monitors contractors’ performance and management systems to ensure that cost, product, and performance are in compliance with the contract terms. DCMA generally maintains contract financing payment data for the contracts it administers. Personnel from DCMA are sometimes consulted in the development of performance-based payment agreements. Further, because officials from DCMA are often located within manufacturing plants for DOD contractors, they may provide contracting officers with insight into contractor processes. This insight could help inform milestones events.

Effect of Financing on Contract Profit and Pricing

When negotiating certain noncommercial contracts, DOD requires contracting officers to use a structured approach—typically the weighted guidelines method—to develop profit level goals for individual defense contracts.⁹ As part of their efforts to determine the government’s negotiating position, contracting officers will consider the amount of financing the government plans to pay the contractor, which can affect how much profit a contractor will receive on a particular contract. The weighted guidelines in DOD’s acquisition regulation suggest that, when other factors are held constant, profit will usually be 1 to 2 percent lower when the government provides financing. In addition to considering whether contract financing is offered, contracting officers consider other elements when establishing the government’s negotiating position, which may also affect the profit goal.¹⁰ Lower profit allows for lower contract prices for the government. However, we reported in 2019 that a company’s internal rate of return—one measure of profitability—can be significantly higher on contracts receiving financing when compared to contracts that are self-financed or use commercially borrowed funds.¹¹

DOD’s Contract Finance Study

In our June 2019 report, we found that DOD had not performed a comprehensive assessment of contracting financing in over 35 years and recommended that DOD undertake such a study.¹² In response to our recommendation, DPC initiated a review of the effects of financing on the defense industry over the previous 20 years. It contracted with three universities and one federally funded research and development center to research the following areas: (1) the financial health of the defense industry, (2) cash flow in the defense industry, (3) the effects of contract financing on small business, and (4) financing considerations in the commercial marketplace. Additionally, DPC analyzed, among other

⁹Noncommercial contracts refer to other than a commercial purchase, meaning contracts for solutions not available commercially and developed specifically for government that do not meet the definition of commercial products or services. See FAR 2.101

¹⁰The other three profit factors that are to be considered include performance risk, facilities capital employed, and cost efficiency. DFARS 215.404-71. The facilities capital employed factor focuses on encouraging and rewarding capital investment in facilities that benefit DOD. DFARS 215.404-71-4.

¹¹[GAO-19-406](#). In this report we also stated that DOD’s 2001 Incentives Guidebook notes that internal rate of return is one of the basic tools used by industry to determine where to invest its funds and assess the risks and potential rewards involved in contracting with the government or commercial entities. Internal rate of return is a measure that integrates both the contractor’s investment to produce the product and the profit earned on that product.

¹²[GAO-19-406](#).

things, how quickly payments to prime contractors flowed down to subcontractors on defense contracts. DPC compiled the findings from its studies and sought public comment on contract financing and payments terms prior to issuance of its final report in April 2023.

DOD's study reported that the defense industry is financially healthy and that its financial health has improved over time. It also stated that DOD's contract financing policies generously support the prime contractors' cash flows. However, the study noted that defense subcontractors and suppliers generally do not receive as favorable cash flow from prime contractors as prime contractors receive from DOD through contract financing. The study stated that small businesses are especially vulnerable to slow payments from prime contractors, which may cause financial strain. The report contained 16 proposed actions that DOD anticipates will further support the defense industrial base. These proposed actions support areas of concern that are highlighted in DOD's report, such as the importance of cash flow to contractors, timely payments to subcontractors and small businesses, and the effectiveness of performance-based payments.

Several Factors Influence Financing Option Used, with Progress Payments Outpacing Performance-Based Payments

Several Factors Influence Contracting Officers' Financing Decisions

Contracting officers we spoke with stated that several factors influence their decision when deciding between progress or performance-based payments. They stated that contractors generally expect that financing will be offered on capital intensive contracts, but certain circumstances may dictate which form is best suited for an individual procurement. The key factors they identified that drive their decisions include (1) the ability to define objective milestones, (2) the time available to award the contract, (3) the approval or disapproval of a contractor's accounting system, (4) the contractor's financing preference, and (5) whether there is a mutual benefit to the government and contractor. These factors are discussed below.

-
- **Ability to define objective milestones.** Contracting officers we spoke with noted that performance-based payments typically only work when contract requirements allow for objectively measurable payment milestones. Several contracting officers noted that established weapon system programs lend themselves to contracts with performance-based payments because manufacturing processes are in place, making it easier to identify objective milestones. In addition, they stated that these programs have historical pricing data that can help establish milestone payments.

Several of the contracts we reviewed used performance-based payments to procure weapon systems or system components. For example, a contract for radars for an aircraft modernization program defined delivery of antennas or assembled motherboards as some of the milestone events tied to performance-based payments. Further, the contracting officer had historical pricing data that could help establish milestone payments. In another example, a Navy cruise missile production contract used 17 milestone payment events, including the receipt and fabrication of component parts on a specified number of missiles. The performance-based payments plan for this contract estimated the first payment to be made 4 months after the contractor received the order to proceed with production and the last at 28 months. The payments associated with these milestones represented approximately 77 percent of the contract value over that time.

- **Time available to award the contract.** Air Force contracting officers noted that urgent-need procurements are better suited for progress payments. According to these officials, it can take a long time to negotiate performance-based milestone events and payments. In a program that needs to field a requirement quickly, the time required for performance-based payment negotiations may result in warfighters not getting what they need in a timely manner. Air Force contracting officers noted that progress payments, on the other hand, do not require negotiations. Additionally, several contracting officers stated that a contractor needs to ask for performance-based payments early in the contract negotiating process or the contract award could take several months beyond the already lengthy award process.¹³
- **Status of contractor's accounting system.** One contracting officer we spoke with stated that performance-based payments were used on

¹³We recently issued a report on DOD's procurement administrative lead times. See GAO, *Defense Contracts: Better Monitoring Could Improve DOD's Management of Award Lead Times*, [GAO-24-106528](#) (Washington, D.C.: Mar. 14, 2024).

a contract for light utility helicopters because the contractor did not have a government-compliant accounting system, which is a requirement to receive progress payments.¹⁴ Because of this, the government and the contractor agreed to identify payment milestones and used performance-based payments since these do not require a government-compliant accounting system.

- **Contractor's financing preference.** Several contracting officers stated that performance-based payments are generally not used unless they are requested by the contractor. In their experience, some contractors prefer progress payments over performance-based payments. Several other contracting officers stated that requests for performance-based payments are usually initiated by the contractor, but the contracting officer might suggest their use as it may lead to lower prices on the contract.
- **Mutual benefit of government and contractor.** Multiple contracting officers noted that performance-based payments should be used when both the government and contractor benefit. For example, one contracting officer stated that when a contractor receives performance-based payments, the contractor receives needed cash flow. At the same time, the contractor may offer a discount on the price of the contract or speed up deliveries to receive performance-based payments. For example, contract documents for a Navy helicopter program in production stated that using performance-based payments was one of the factors that contributed to a 7 percent cost reduction from the previous production contract. The program's cash flow comparison analysis, which compared the financial effects of progress payments to performance-based payments, indicated that the contractor would also have an increased internal rate of return with performance-based payments.

In some cases, a mutual benefit may not exist for using performance-based payments. In one instance, an Air Force official stated that a contractor wanted to switch from progress payments to performance-based payments. However, the official suggested that the contractor continue to receive progress payments because there was concern that the contractor would not be able to meet milestones, which could reduce the contractor's cash flow. A reduction in cash flow could further weaken the contractor's performance, which could delay delivery to the warfighter.

¹⁴For more information on accounting systems, see GAO, *Contractor Business Systems: DOD Needs Better Information to Monitor and Assess Review Process*, [GAO-19-212](#) (Washington, D.C.: Feb. 7, 2019).

The factors identified by contracting officers we spoke with reflect what DOD guidance states should be considered when determining financing options. Specifically, DOD guidance states that performance-based payments may be more suitable for mature programs in production. This is because repeated tasks and historical cost data make identifying payment events and financing needs easier to estimate. In addition, this guidance notes that progress payments may be more suited to small-value contracts because the administrative effort to establish a performance-based agreement may exceed the financing benefits attained.

DOD Provided More Progress Payments Than Performance-Based Payments Since 2015

Based on our analysis of DOD data, we found that DOD generally increased its use of both types of financing, with more funds being provided through progress payments since 2015 (see fig. 2). Additionally, DOD reported that the department uses some form of financing on the majority of its noncommercial, fixed-price contracts.

Figure 2: Department of Defense (DOD) Progress and Performance-based Payments, Fiscal Years (FY) 2013-2023

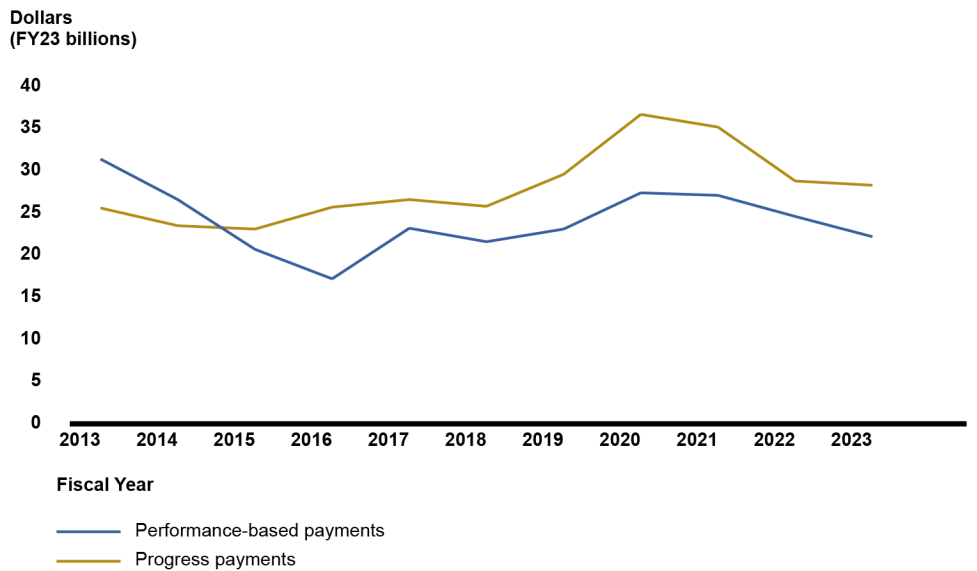

Source: GAO analysis of DOD data from the Mechanization of Contract Administration Services system. | GAO-24-106850

Fiscal year 2023 data also show that the two types of financing were used for similar commodities (see fig. 3).

Figure 3: Comparison of the Department of Defense's (DOD) Progress and Performance-based Payments by Commodity, Fiscal Year 2023

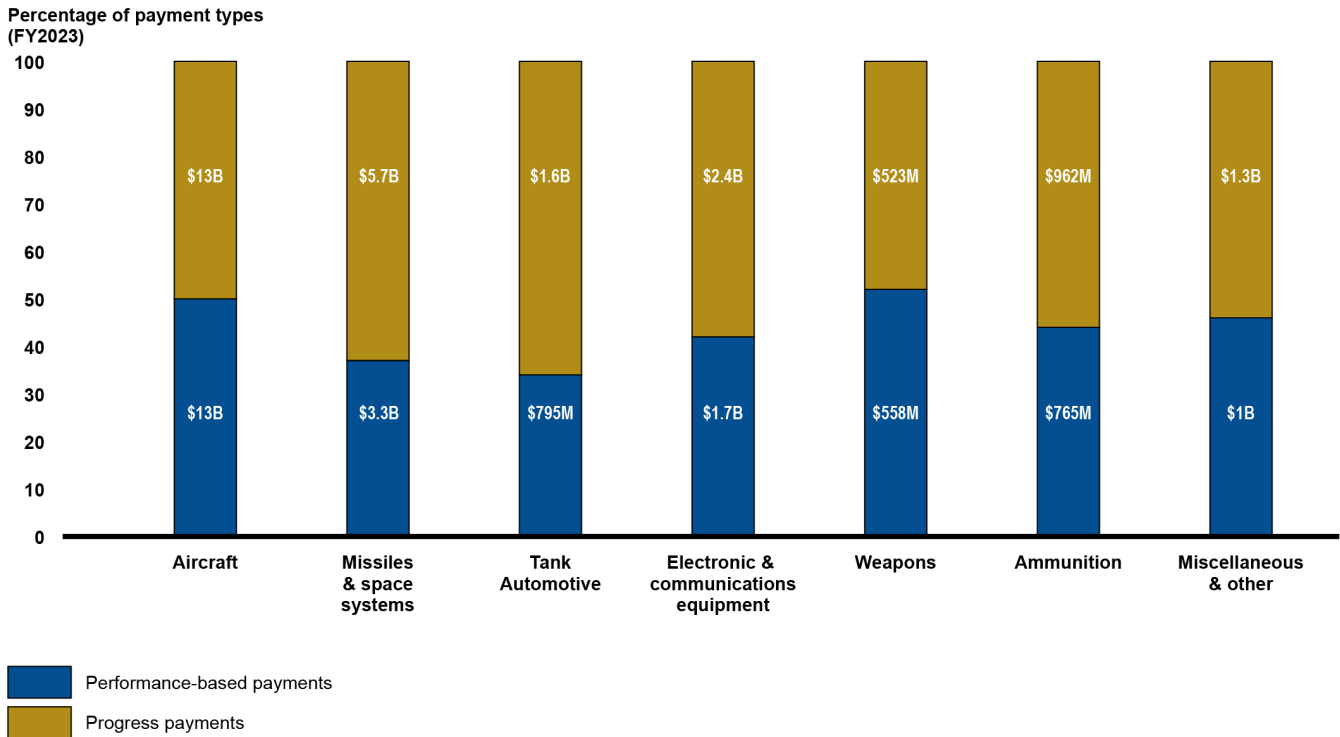

Source: GAO analysis of DOD data from the Mechanization of Contract Administration Services system. | GAO-24-106850

One example of a program that used both forms of financing is the F-35 aircraft. The production contract used to procure multiple lots of aircraft used performance-based payments. The contracting officer stated that the contractor has an established manufacturing process that lends itself to measurable milestones. Further, this contracting officer stated that the program leveraged knowledge from previous production lots to establish objective milestones. In contrast, the sustainment contract uses progress payments. The contracting officer responsible for that contract stated that the changing requirements in the sustainment contract make it difficult to establish objective milestones. That contracting officer stated that the number of aircraft that need maintenance or repair fluctuates from month to month.

DOD’s Proposed Actions Are in Various Stages of Completion

As of January 2024, DOD had started or completed 13 of the 16 proposed actions identified in its April 2023 contract financing study. DPC officials anticipate that most of its ongoing or remaining actions will require regulatory changes, which they noted can take years to complete, or involve developing additional tools and training.¹⁵ Additionally, DPC officials stated that the time it takes to implement the proposed actions will be based on the resources available to DPC. Table 2 summarizes DOD’s proposed actions and their status as of January 2024. Further explanation of the action items follows the table.

Table 2: Time Frames and Status of DOD’s Proposed Contract Finance Actions, as of January 2024

Projected timeline ^a	Proposed action	Status
	No Action	
Not applicable	• Retain existing profit approach (do not adjust weighted guidelines methodology, which is a structured approach used to develop profit objectives for negotiating individual defense contracts)	Complete
	• Retain existing policy that interest related to financing is an unallowable cost	Complete
	Policy Change	
	• Return to a customary progress payment rate of 80 percent for large businesses from 90 percent during the declared emergency for COVID-19, in a manner that minimizes disruption	Complete
	• Retain the 95 percent progress payment rate introduced in March 2020 during the declared emergency for COVID-19, for small businesses ^b	Complete
	Tools and Training	
Near-term (6-12 months)	• Evaluate, improve, and disseminate a new Department of Defense (DOD) Contract Cash Flow Model	Ongoing
	Regulatory Change	
Mid-term (1-3 years)	• Improve the ability of subcontractors to contact the contracting officer when they do not receive payments from prime contractors	Ongoing
	• Improve the implementation of faster payments to subcontractors from prime contractors	Ongoing
	• Modify various regulations, as needed, to improve timely payments from prime contractors to subcontractors, including small businesses	Ongoing
	• Explore and pilot a new form of contract financing to meet the general financing needs of small businesses	Ongoing
	• Consider other payment protections for subcontractors not already listed in the actions above	Ongoing

¹⁵We previously reported that changes to regulations, such as the DFARS, can take years to complete. The following reports describe time frames to make changes to federal and defense regulations: GAO, *Defense Acquisitions: DOD Should Take Additional Actions to Improve How It Approaches Intellectual Property*, [GAO-22-104752](#) (Washington, D.C.: Nov. 30, 2021); and *Defense Acquisitions: DOD Needs to Improve How It Communicates the Status of Regulation Changes*, [GAO-19-489](#) (Washington, D.C.: July 11, 2019).

Projected timeline ^a	Proposed action	Status
	Tools and Training	
	<ul style="list-style-type: none"> Educate the acquisition workforce (on cash flow) in cooperation with the Defense Acquisition University 	Ongoing
	<ul style="list-style-type: none"> Educate businesses and DOD stakeholders on accounting system requirements to counteract perceived challenges of these systems 	Not started
	Miscellaneous	
	<ul style="list-style-type: none"> Study the cost and effectiveness of the use of performance-based payments 	Ongoing
	Pursue Legislative Change	
Far-term (more than 3 years)	<ul style="list-style-type: none"> Extend the prime contractor benefit of Prompt Payment—generally being paid within 30 days—to subcontractors 	Ongoing
	Regulatory Change	
	<ul style="list-style-type: none"> Explore the use of a higher-than-customary progress payment rate to motivate or reward large businesses^c 	Not started
	Miscellaneous	
	<ul style="list-style-type: none"> Improve subcontractor payment oversight (by exploring the role of DOD’s business systems reviews^d) 	Not started

Source: GAO analysis of Defense Pricing and Contracting information. | GAO-24-106850

^aThe Defense Pricing and Contracting office defined these implementation timelines with respect to the publication date of its April 2023 Contract Financing study.

^bDOD Class Deviation 2020-O0010, March 20, 2020.

^cThe National Defense Authorization Act for Fiscal Year 2024, Pub. L. No. 118-31, § 874 (2023) has a provision that DOD implement a pilot program to incentivize contractors’ performance by offering up to 10 percent higher than the customary progress payment rate.

^dA contractor’s business system can include an accounting system, cost estimating system, or property management system.

As the table above shows, the proposed actions are in various stages of completion, from fully completed to not started. For example, DPC has fully completed four proposed actions:

- **Retain weighted guidelines.** DOD determined that the existing method to determine profit objectives in contracts—generally the weighted guidelines—is the most appropriate method.
- **Maintain that interest is an unallowable cost.** Federal regulations identify interest expenses related to financing as unallowable, directing government agencies to exclude these from billings, claims, and proposals on government contracts. DOD reported in the contract finance study that interest, which is an expense incurred in the ordinary conduct of business, should remain an unallowable cost. DOD concluded that if the government paid for interest incurred by contractors, then contract prices would increase, costing the government more money.

-
- **Revert to 80 percent for large businesses.** During the COVID-19 pandemic, DOD increased the progress payment rate for large businesses to 90 percent.¹⁶ DOD did this to help stabilize the defense industrial base with the understanding that the increased financing would flow down to subcontractors and suppliers. However, DOD determined that the additional cash flow from the increased rate to large contractors had a limited effect on subcontractors and suppliers. This, coupled with the end of the pandemic, resulted in DOD concluding that reverting to 80 percent rate for large businesses was appropriate.¹⁷
 - **Retain 95 percent progress payment rate for small businesses.** During the COVID-19 pandemic, DOD increased the progress payment rate for small businesses to 95 percent.¹⁸ DOD undertook this change to help small businesses with cash flow during the pandemic, particularly small firms at lower levels of the supply chains. DOD studied the effects of this rate change and determined the increased rate was beneficial for small businesses. As a result, DOD decided to maintain the 95 percent payment rate for small businesses.

DPC has also taken initial steps toward eight of the proposed actions, with some actions closer to completion than others. For example:

- **Create a cash-flow model.** DPC is working on releasing a new cash-flow model to educate contracting officers and pricing experts on the value of cash flow. The new model is intended to show these officials the importance of cash-flow to contractors and that profit is not the only factor contractors focus on during contract negotiations. Cash-flow is important because contractors need to have enough cash available to cover their expenses—such as labor, materials, and overhead—and to be able to purchase assets before delivery of the contracted item. The DOD report noted that “cash is king” to underscore the importance of cash in business.

DPC introduced the model in spring 2023 and a DPC official told us that their team had various groups test it within DOD. According to a DPC official, DPC updated the model with user feedback and plans on

¹⁶FAR 52.232-16; (DOD Class Deviation 2020-O0010, March 20, 2020).

¹⁷For more information on DOD’s use of increased progress payments during the COVID-19 pandemic, see GAO, *Defense Contracting: More Insight into Use of Financing Payments Could Benefit DOD in Future Emergencies*, [GAO-22-105007](#) (Washington, D.C.: Feb 17, 2022).

¹⁸DFARS 252.232-7004; (DOD Class Deviation 2020-O0010, March 20, 2020).

releasing it for widespread use in spring 2024. DPC noted that it was working on an enhanced version, which will include user-requested features that will be released at a later date. Several DOD contracting officers stated they had not seen or used the model, but expressed interest in its use. DPC officials stated that they are working with the Defense Acquisition University to incorporate training on the importance of cash flow to contractors and the use of the model. According to DPC officials, they are still exploring if the use of this tool will be mandatory.

- **Extend payment protections for subcontractors.** DOD has also started steps for several of the proposed actions related to payment protections for subcontractors. The April 2023 contract financing study noted that improvements to cash flow for defense subcontractors and suppliers can be made. For example:

1. DOD is looking into extending Prompt Payment terms, currently applicable to prime contractors only, to subcontractors by pursuing a legislative change.¹⁹ DOD officials stated that the change would be particularly beneficial to small business subcontractors and established a Small Business Payment Improvement working group to examine the proposal further. One challenge related to this, expressed by several DOD officials, is that the data needed to track prime contractors' payments to subcontractors are not available to the government. This is, in part, because the federal government's direct contractual relationship is with the prime contractor and not with the subcontractor. This generally means that the government does not have insight into terms between prime contractors and their subcontractors and other suppliers. DPC recognizes this challenge and is leveraging the Small Business working group to work on this data issue.

Several industry representatives also noted concerns with extending the Prompt Payments clause to subcontractors because it would require increased DOD insight into the prime-subcontractor relationship. Industry representatives noted that contractors often have their own dispute mechanisms, which eliminates the need for DOD contracting officers to intervene in the prime-subcontractor relationship.

¹⁹The Prompt Payment Act, as amended, requires the government to establish the due date, generally 30 days, for payments under a contract and pay interest on the amount due when a payment is not made by the due date. 31 U.S.C. §§ 3902-3903. See, for example, FAR 52.232-25.

2. In addition to extending the Prompt Payment terms, DPC proposed (a) accelerating payments from prime contractors to all subcontractors, not just small business subcontractors, (b) improving the ability of subcontractors to contact the contracting officer when they do not receive payments from prime contractors, (c) modifying various regulations to improve timely payments from prime contractors to subcontractors, including small businesses, and (d) considering other payment protections for subcontractors not already listed. DPC officials stated that before they can implement these actions, they need to gather information about the potential effects the actions may have on the industrial base. DPC received dozens of public comments on these topics and the extension of the Prompt Payment clause in September 2023, which it is currently reviewing and analyzing. Most of the respondents, especially small businesses, supported extending Prompt Payment provisions to subcontractors.

- **Study the effectiveness of the use of performance-based payments.** DPC is examining if performance-based payments are resulting in contract award delays and consuming more resources than warranted. In addition, DPC is reviewing if, under current practices, DOD is unintentionally providing payments to contractors before contractors need the cash, which is contrary to the intent of performance-based payments. This can occur because, according to the DOD contract finance study, DOD negotiates performance-based payments on forecasts of expected monthly costs incurred. Because of this, DOD found that it is possible to exceed actual costs incurred in performance-based payment contracts.

Finally, DOD has not taken any steps on four of the proposed actions.

- **Introduce pilot program for small business prime contractors.** DPC is envisioning a pilot program focused on a new form of contract financing to meet the general financing needs of small businesses as a way to attract them to the defense industrial base. However, DPC officials said that prior to launching any pilot program, it needs to collect information on how businesses may want to use it. DPC aims to conduct data analysis and gather stakeholder input, as well as obtain public comments for this pilot program. DPC officials stated that the earliest this project would start is fiscal year 2024 and provided no further details on what the pilot may include.
- **Educate regarding accounting system requirements.** DPC also plans to educate businesses and DOD stakeholders on accounting system requirements to counteract perceived challenges of these

systems. DOD found that these requirements are perceived as onerous by companies seeking government financing, and thus a barrier to attracting new businesses. However, DOD's contract finance study concluded that most of the companies doing business with DOD would not need to meet any government-unique requirements. For example, DOD concluded that very few companies—around 12 percent from 2019 to 2021—had contracts that required government-compliant accounting systems, the type required to receive progress payments.²⁰ The report also found, however, that when these requirements do apply, companies can find it challenging to adapt commercial accounting systems to meet government requirements. DOD concluded that education on this topic is important to attract new entrants to the defense industrial base. DPC officials stated they first need to discuss this topic with relevant DOD stakeholders and potentially obtain public comments on the initiative.

- **Use of a higher than customary progress payment rate to motivate or reward large businesses.** DPC officials stated they had not yet taken any action because this recommendation would require extensive resources and is a lower priority compared to some of the other proposed actions. Section 874 of the National Defense Authorization Act for Fiscal Year 2024 requires the Under Secretary for Acquisition and Sustainment to implement a pilot program to incentivize contractors' performance by offering up to 10 percent higher than the customary progress payment rate.²¹ The act allows the Under Secretary to establish a pilot through fiscal year 2029. A DPC official noted that this gives DPC sufficient time to implement the program in a deliberate manner.
- **Improve subcontractor payment oversight.** DPC plans to explore ways to improve the government's insights into the prime contractors' payments to subcontractors and whether this could be accomplished through DOD's reviews of business systems. DPC officials stated that this needs to be a discussion with DCMA, which oversees contractor business system reviews. DPC held a DOD-wide Payment Improvement Summit in December 2023 and established a working group following the summit to explore a range of topics, including government insight into the timeliness of prime contractors' payments

²⁰The requirement for a defined accounting system applies to noncommercial contracts that are cost-reimbursable, incentive type, such as fixed-price incentive, time and materials and labor hour, and contracts regardless of type that include progress payments based on costs or on a percentage or stage of completion.

²¹Pub. L. No. 118-31 (2023).

to subcontractors. DPC expects to discuss this topic with DCMA at the next working group meeting, including how it can gain insights into payment timeliness at a systemic level, such as during a DCMA business system review. Additionally, DPC officials stated they need to determine what type of action is needed—training or a regulation change—to implement this proposed action.

Agency Comments

We provided a draft of this report to the Department of Defense for review and comment. DOD provided written comments, which are reprinted in appendix I.

We are sending copies of this report to the appropriate congressional committees and the Secretary of Defense; the Under Secretary of Defense for Acquisition and Sustainment; the Principal Director, Defense Pricing and Contracting; the Director, Defense Contract Management Agency; and the Director, Office of Management and Budget. In addition, the report is available at no charge on the GAO website at <http://www.gao.gov>.

If you or your staff have any questions about this report, please contact me at (202) 512-4841 or SehgalM@gao.gov. Contact points for our Offices of Congressional Relations and Public Affairs may be found on the last page of this report. GAO staff who made key contributions to this report are listed in appendix II.



Mona Sehgal
Director, Contracting and National Security Acquisitions

List of Committees

The Honorable Jack Reed
Chairman
The Honorable Roger Wicker
Ranking Member
Committee on Armed Services
United States Senate

The Honorable Jon Tester
Chair
The Honorable Susan Collins
Ranking Member
Subcommittee on Defense
Committee on Appropriations
United States Senate

The Honorable Mike Rogers
Chairman
The Honorable Adam Smith
Ranking Member
Committee on Armed Services
House of Representatives

The Honorable Ken Calvert
Chair
The Honorable Betty McCollum
Ranking Member
Subcommittee on Defense
Committee on Appropriations
House of Representatives

Appendix I: Comments from the Department of Defense



ACQUISITION
AND SUSTAINMENT

OFFICE OF THE UNDER SECRETARY OF DEFENSE
3000 DEFENSE PENTAGON
WASHINGTON, DC 20301-3000

Ms. Mona Sehgal
Director, Contracting and National Security Acquisitions
U.S. Government Accountability Office
441 G Street, NW
Washington DC 20548

Dear Ms. Sehgal:

This is the Department of Defense (DoD) response to the Government Accountability Office (GAO) Draft Report GAO-24-106850, “CONTRACT FINANCING: Factors That Influence the Use of Financing Methods and DoD’s Progress on Proposed Actions,” dated April 9, 2024 (GAO Code 106850).

The Department acknowledges receipt of the draft report and notes that it contains no recommendations. DoD is proud of its work on the Defense Contract Finance Study, a comprehensive effort to assess defense industry financial performance over a twenty-year timeframe, using a data-driven approach. The areas examined by the Study—financial health of the industrial base, financing regulations, insight into the commercial marketplace, and impacts to subcontractors, including small businesses—have enduring importance and the Study will continue to guide our work in these areas for years to come.

Sincerely,

TENAGLIA. Digitally signed by
JOHN.M.11 TENAGLIA, JOHN.M.
54945926 1154945926
Date: 2024.05.03
11:48:54 -04'00'

John M. Tenaglia
Principal Director,
Defense Pricing and Contracting

Appendix II: GAO Contact and Staff Acknowledgments

GAO Contact

Mona Sehgal, (202) 512-4841, or sehgal@gao.gov

Staff Acknowledgments

In addition to the contact named above, Tatiana Winger (Assistant Director), Victoria Klepacz (Analyst-in-Charge), Adriana Aldgate, Rachel Binder, Lorraine Ettaro, Stephanie Gustafson, Courtney LaFountain, Anne Louise Taylor, Thomas Twambly, Alyssa Weir, and Adam Wolfe made key contributions to this report.

GAO's Mission

The Government Accountability Office, the audit, evaluation, and investigative arm of Congress, exists to support Congress in meeting its constitutional responsibilities and to help improve the performance and accountability of the federal government for the American people. GAO examines the use of public funds; evaluates federal programs and policies; and provides analyses, recommendations, and other assistance to help Congress make informed oversight, policy, and funding decisions. GAO's commitment to good government is reflected in its core values of accountability, integrity, and reliability.

Obtaining Copies of GAO Reports and Testimony

The fastest and easiest way to obtain copies of GAO documents at no cost is through our website. Each weekday afternoon, GAO posts on its [website](#) newly released reports, testimony, and correspondence. You can also [subscribe](#) to GAO's email updates to receive notification of newly posted products.

Order by Phone

The price of each GAO publication reflects GAO's actual cost of production and distribution and depends on the number of pages in the publication and whether the publication is printed in color or black and white. Pricing and ordering information is posted on GAO's website, <https://www.gao.gov/ordering.htm>.

Place orders by calling (202) 512-6000, toll free (866) 801-7077, or TDD (202) 512-2537.

Orders may be paid for using American Express, Discover Card, MasterCard, Visa, check, or money order. Call for additional information.

Connect with GAO

Connect with GAO on [Facebook](#), [Flickr](#), [Twitter](#), and [YouTube](#).
Subscribe to our [RSS Feeds](#) or [Email Updates](#). Listen to our [Podcasts](#).
Visit GAO on the web at <https://www.gao.gov>.

To Report Fraud, Waste, and Abuse in Federal Programs

Contact FraudNet:

Website: <https://www.gao.gov/about/what-gao-does/fraudnet>

Automated answering system: (800) 424-5454 or (202) 512-7700

Congressional Relations

A. Nicole Clowers, Managing Director, ClowersA@gao.gov, (202) 512-4400, U.S. Government Accountability Office, 441 G Street NW, Room 7125, Washington, DC 20548

Public Affairs

Chuck Young, Managing Director, youngc1@gao.gov, (202) 512-4800
U.S. Government Accountability Office, 441 G Street NW, Room 7149
Washington, DC 20548

Strategic Planning and External Liaison

Stephen J. Sanford, Managing Director, spel@gao.gov, (202) 512-4707
U.S. Government Accountability Office, 441 G Street NW, Room 7814,
Washington, DC 20548



Please Print on Recycled Paper.