



---

October 2017

# SOLID ROCKET MOTORS

## DOD and Industry Are Addressing Challenges to Minimize Supply Concerns

Accessible Version

# GAO Highlights

Highlights of [GAO-18-45](#), a report to the Honorable Joe Manchin III, U.S. Senate

## Why GAO Did This Study

DOD relies on a multi-tiered supply chain to provide SRMs, the propulsion systems behind the various missile systems that provide defense capabilities to meet U.S. national security objectives. The SRM industrial base includes manufacturers that turn to an extensive network of suppliers that provide the raw materials, components, and subsystems needed to build SRMs. DOD is responsible for developing a strategy for the national industrial base that ensures that defense contractors and their suppliers are capable of providing the goods and services needed to achieve national security objectives.

GAO was asked to review the state of the U.S. industrial base for SRMs. This report addresses (1) SRM industry trends, (2) single source supplier risks, and (3) opportunities for SRM manufacturers' engineering workforce development. GAO analyzed DOD's annual industrial capabilities reports to Congress for fiscal years 2009 through 2016, which reflect DOD's most current information on SRM risks, and reviewed DOD budget data and information from missile prime contractors and SRM manufacturers. GAO also interviewed missile prime contractors, SRM manufacturer representatives, and officials from DOD and the military departments.

## What GAO Recommends

GAO is not making recommendations at this time.

View [GAO-18-45](#). For more information, contact Marie A. Mak at (202) 512-4841 or [makm@gao.gov](mailto:makm@gao.gov).

October 2017

# SOLID ROCKET MOTORS

## DOD and Industry Are Addressing Challenges to Minimize Supply Concerns

### What GAO Found

Over the past two decades, the solid rocket motor (SRM) industrial base has undergone various changes including consolidation and recent expansion. Specifically, since 1995, the industry has consolidated from six U.S. manufacturers to two U.S. manufacturers. With regard to expansion, a foreign supplier entered the market in 2012, and in 2017, a U.S. firm, which is ultimately foreign-owned, was also established. According to the Department of Defense (DOD) while it supports competition, its current demand for SRMs can only sustain two manufacturers. Although at this stage it is too early to know how, or if, these new entrants will impact the economic viability of the more long-standing U.S. manufacturers.

Industry Trends of Solid Rocket Motor Manufacturers since 1995

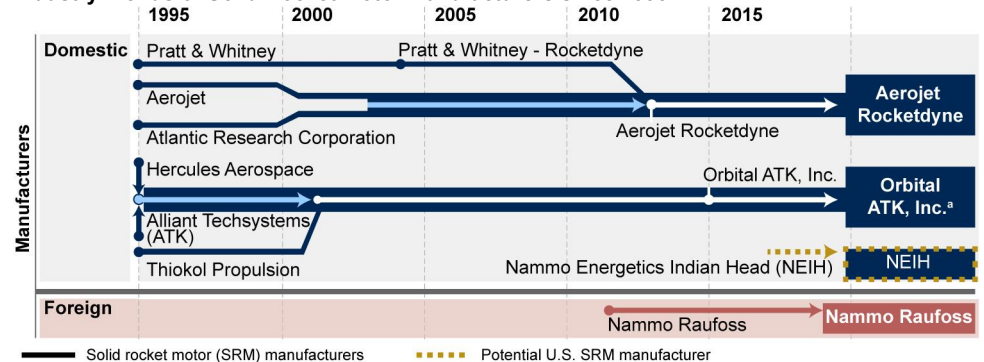

Source: GAO presentation of Department of Defense and industry information. | GAO-18-45

<sup>a</sup>In September 2017, Northrup Grumman announced plans to acquire Orbital ATK, Inc.

The consolidation in the SRM industrial base has also been accompanied by a decrease of suppliers throughout the supply chain. For example, one SRM manufacturer estimated a decrease in suppliers, from approximately 5,000 to 1,000, over the last 20 years. This increases the risk of production delays and disruptions in the event that key components and materials available from a single source become unavailable from that source. GAO found that DOD and industry are taking steps to identify and mitigate these risks, such as by establishing alternative sources and requiring advance notice when suppliers are considering exiting the market.

In its annual industrial capabilities reports to Congress, DOD has consistently stated that the limited number of new missile development programs inhibits its ability to provide opportunities to help SRM manufacturers maintain their workforce capabilities. Specifically, with few new missile programs being initiated, engineers have had fewer opportunities to develop their engineering skills related to SRM concept designs, system development, and production, which are critical if SRM performance issues arise. However, in 2016, DOD funded a 4-year project to enhance engineering design skills for less experienced engineers working for the two U.S. manufacturers and help them develop advanced SRM technologies.

---

# Contents

---

|   |   |    |
|---|---|----|
| Letter  |   | 1  |
|   | Background  | 3  |
|   | Industry Trends Create Uncertainty for U.S. Solid Rocket Motor Suppliers                                  | 8  |
|   | Single Source Suppliers Drive Material Availability Risks but Mitigation Actions Underway                 | 11 |
|   | Manufacturing Engineers' Solid Rocket Motor Design Skills Declining but Workforce Project Initiated       | 16 |
|   | Agency Comments   | 18 |
| <hr/>   |   |    |
| Appendix: GAO Contact and Staff Acknowledgments |   | 19 |
|   | GAO Contact   | 19 |
|   | Staff Acknowledgments   | 19 |
| <hr/>   |   |    |
| Table   |   |    |
|   | Table 1: Department of Defense (DOD) and Industry Actions to Address Certain Single Source Supplier Risks | 15 |
| <hr/>   |   |    |
| Figures   |   |    |
|   | Figure 1: Notional Illustration of a Solid Rocket Motor   | 4  |
|   | Figure 2: Notional Illustration of a Solid Rocket Motor Supply Chain                                      | 6  |
|   | Figure 3: Industry Trends of Solid Rocket Motor Manufacturers since 1995                                  | 9  |
| <hr/>   |   |    |
| <b>Abbreviations</b>                            |   |    |
| AMRAAM  | Advanced Medium Range Air-to-Air Missile  |    |
| DCMA  | Defense Contract Management Agency  |    |
| DOD   | Department of Defense   |    |
| MIBP  | Manufacturing and Industrial Base Policy  |    |
| NEIH  | Nammo Energetics Indian Head, Inc.  |    |
| NASA  | National Aeronautics and Space Administration   |    |
| SRM   | solid rocket motor  |    |

---

---

This is a work of the U.S. government and is not subject to copyright protection in the United States. The published product may be reproduced and distributed in its entirety without further permission from GAO. However, because this work may contain copyrighted images or other material, permission from the copyright holder may be necessary if you wish to reproduce this material separately.



October 26, 2017

The Honorable Joe Manchin III  
United States Senate

Dear Mr. Manchin:

The Department of Defense (DOD) relies on multiple types of missiles—including tactical missiles used for short distances, longer-range strategic missiles, and missile defense systems to intercept enemy missiles—to provide essential defense capabilities. Many of these missiles are powered by solid rocket motor (SRM) propulsion systems, which provide the thrust the missiles need to reach their intended targets. DOD acquires missiles from prime contractors, which in turn contract with other manufacturers to acquire SRMs. Over the past two decades, the number of U.S. companies that manufacture SRMs has consolidated to two manufacturers. These manufacturers rely on a network of suppliers, which have also experienced consolidation, to obtain the raw materials, components and parts needed for the SRM. The consolidation of the supplier base at various levels in the supply chain and decreased demand for SRM materials has reduced competition, and single source suppliers have become more common throughout the supplier network.

Within DOD, the Manufacturing and Industrial Base Policy (MIBP) office claims responsibility for ensuring the health, viability and resiliency of the industrial capabilities that DOD needs. For nearly a decade, MIBP has reported on various challenges that, if left unaddressed, could impede a supplier's ability to provide SRMs for DOD's missile programs. Since at least 2009, DOD has identified the health of the SRM industrial base as an area of concern, driven, in part, by constrained budgets that have led to decreased spending to procure missiles that use SRMs. The Senate Appropriations Committee has also weighed in with concerns—particularly regarding SRMs for tactical missiles such as the Advanced Medium Range Air-to-Air Missile (AMRAAM)—about reduced spending and the use of foreign suppliers.<sup>1</sup>

---

<sup>1</sup>See S. Rep. No. 113-211, at 99-100 (2014).

As a result of these concerns, you asked us to review the state of the U.S. supplier base that provides SRMs for tactical missiles.<sup>2</sup> We examined (1) SRM industry trends, (2) single source supplier risks, and (3) opportunities for SRM manufacturers' engineering workforce development.

To determine SRM industry trends, supplier risks, and workforce opportunities, we reviewed DOD industrial capabilities reports provided to Congress from 2009 to 2016. Three of these reports focused exclusively on DOD's assessment of SRM industrial capabilities—contractors' knowledge, skills, facilities, manufacturing processes, equipment and technologies that enable the production of SRMs.<sup>3</sup> These reports provided insight into the risks to the SRM industrial base and helped us determine actions that DOD has taken to address such risks. Given new entrants to the SRM market for tactical missiles, we reviewed DOD's fiscal year 2009 through 2017 budget data to gain additional insight into its demand for tactical missile programs. We also reviewed information provided by the prime contractors and SRM manufacturers. We interviewed officials from MIBP and the military departments responsible for identifying industrial base risks to determine their processes for identifying, analyzing, and responding to industrial base risks. We also interviewed representatives from the two prime contractors that produce missiles for all of DOD's tactical missile programs as well as some strategic and missile defense programs. In addition, we spoke with officials from the three SRM manufacturers with facilities in the United States to understand the risks to them and their suppliers.

We conducted this performance audit from October 2016 to October 2017 in accordance with generally accepted government auditing standards. Those standards require that we plan and perform the audit to obtain sufficient, appropriate evidence to provide a reasonable basis for our findings and conclusions based on our audit objectives. We believe that

---

<sup>2</sup>GAO's report responds to Senator Manchin's June 2016 request as then-Ranking Member, Senate Armed Services Subcommittee on Airland. This report is part of a body of ongoing work addressing other aspects of industrial base risks including a forthcoming report on DOD's strategy for identifying and prioritizing industrial base risks and implementing risk mitigation efforts.

<sup>3</sup>See for example, Department of Defense, *Solid Rocket Motor Industrial Capabilities Report to Congress*, 2009; *Report to Congress on the SRM Industrial Base Sustainment and Implementation Plan*, 2011; and *Report to Congress on the Industrial Base Assessment of Domestic and Foreign-sourced Tactical SRMs*, 2015.

---

the evidence obtained provides a reasonable basis for our findings and conclusions based on our audit objectives.

---

## Background

---

### Solid Rocket Motors (SRM)

SRMs are the propulsion systems that propel various types of missiles and are also used in space launch activities, including the National Aeronautics and Space Administration's (NASA) Space Shuttle program.<sup>4</sup> Across the military departments, DOD has approximately 40 missile programs that currently use SRMs, including tactical programs such as the Army's Guided Missile Launch Rocket System and the Navy and Air Force AIM-9X Sidewinder.

As shown in figure 1, an SRM consists of a casing filled with solid propellant that, when ignited, expels hot gases through a nozzle to produce thrust. DOD describes the overall SRM components as being consistent among the missile types, although size and scale of propellant requirements vary. For example, tactical missiles use the smallest SRMs—ranging from about 3 inches up to 24 inches in diameter—and require between 3 and almost 1,600 pounds of propellant. Strategic missiles use large SRMs that exceed 40 inches, while missile defense systems utilize both small and large SRMs. Space launch SRMs can exceed 150 inches and can require more than a million pounds of propellant.

---

<sup>4</sup>Space launch activities typically use solid rocket boosters, which contain solid rocket motors, for propulsion.

Figure 1: Notional Illustration of a Solid Rocket Motor

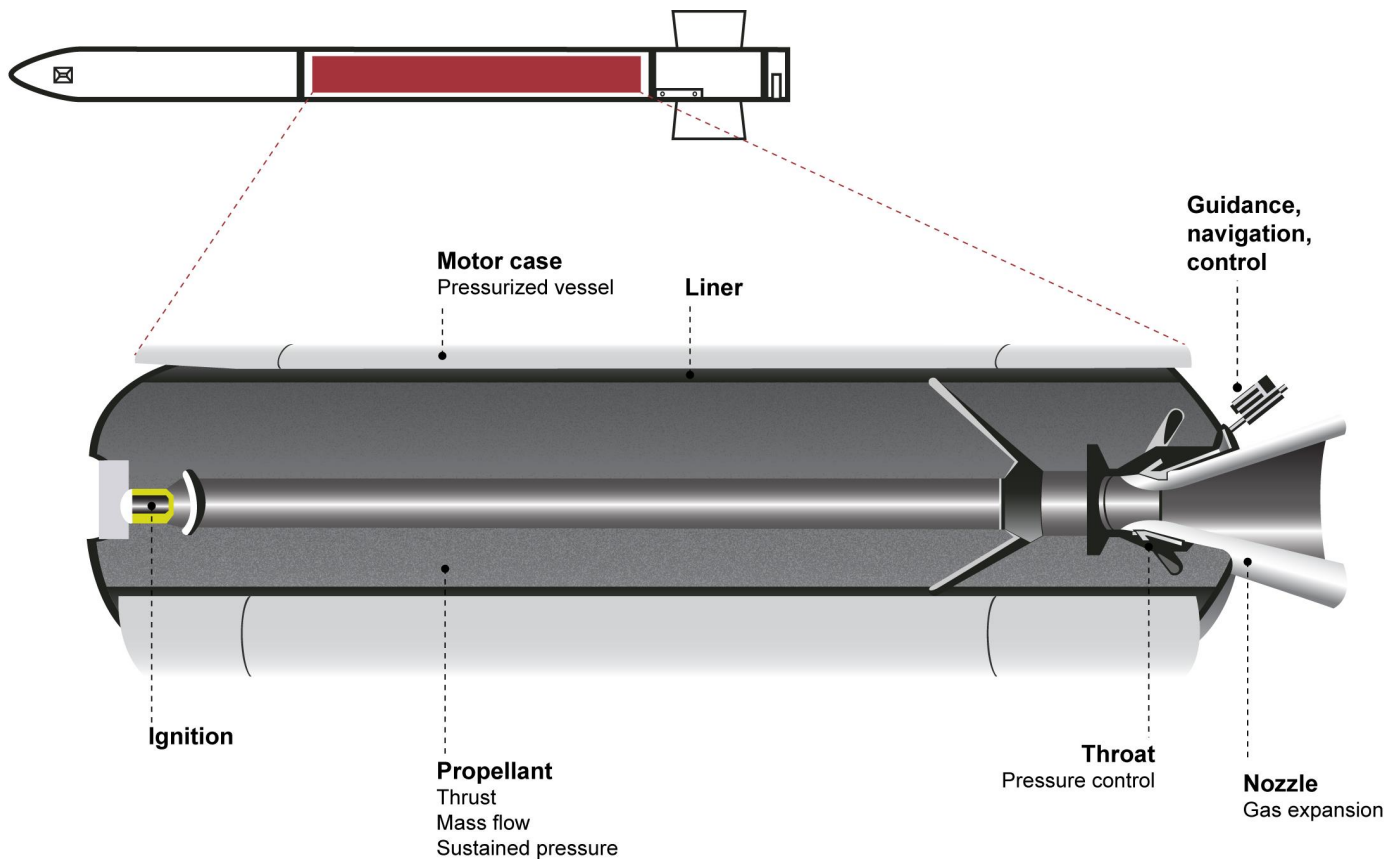

Source: GAO rendering of information provided by Orbital ATK and Department of Defense. | GAO-18-45

In order to be used in a missile, the SRM and its components, such as the propellant ingredients or casing materials, are subject to testing to demonstrate that they meet DOD's technical specifications and requirements. For instance, this testing can confirm that the construction of the SRM allows it to function at certain altitudes or in certain temperatures or environments required by the missile. The SRM is tested as a stand-alone item and as part of the overall missile system before production begins. By successfully completing testing, the missile becomes qualified, and the SRM and its components are deemed suitable to meet the missile's specific requirements going forward. Any changes in the SRM or its components may require additional testing and, if the changes are significant or if there are multiple changes, may require the missile to be retested and thus, requalified—which DOD has noted is an expensive and time-consuming process that can take years and cost millions of dollars.



---

---

## SRM Supply Chain

DOD relies on a multi-tiered supply chain to provide the SRMs that are used for missile propulsion. Industry representatives we spoke to estimate the supply chain extends to more than 1,000 suppliers that provide the raw materials, components, and sub-systems needed to manufacture the SRM. The missile's prime contractors are ultimately responsible for delivering the missiles and for selecting and managing the subcontractors that manufacture the SRM. The SRM manufacturers then subcontract with suppliers that provide the components and materials used to manufacture the SRM. Those suppliers might, in turn, work with another tier of suppliers to meet their needs. For example, an SRM manufacturer may obtain the materials needed for the casing from a first-tier supplier. The first-tier supplier may obtain the materials and components it needs from multiple second-tier suppliers, and so on. According to DOD reports, the SRM supplier base, including the sub-tier suppliers, is nearly identical across missile defense, tactical, and strategic missile systems that use SRMs. Figure 2 is an illustrative version of the SRM supply chain.

Figure 2: Notional Illustration of a Solid Rocket Motor Supply Chain

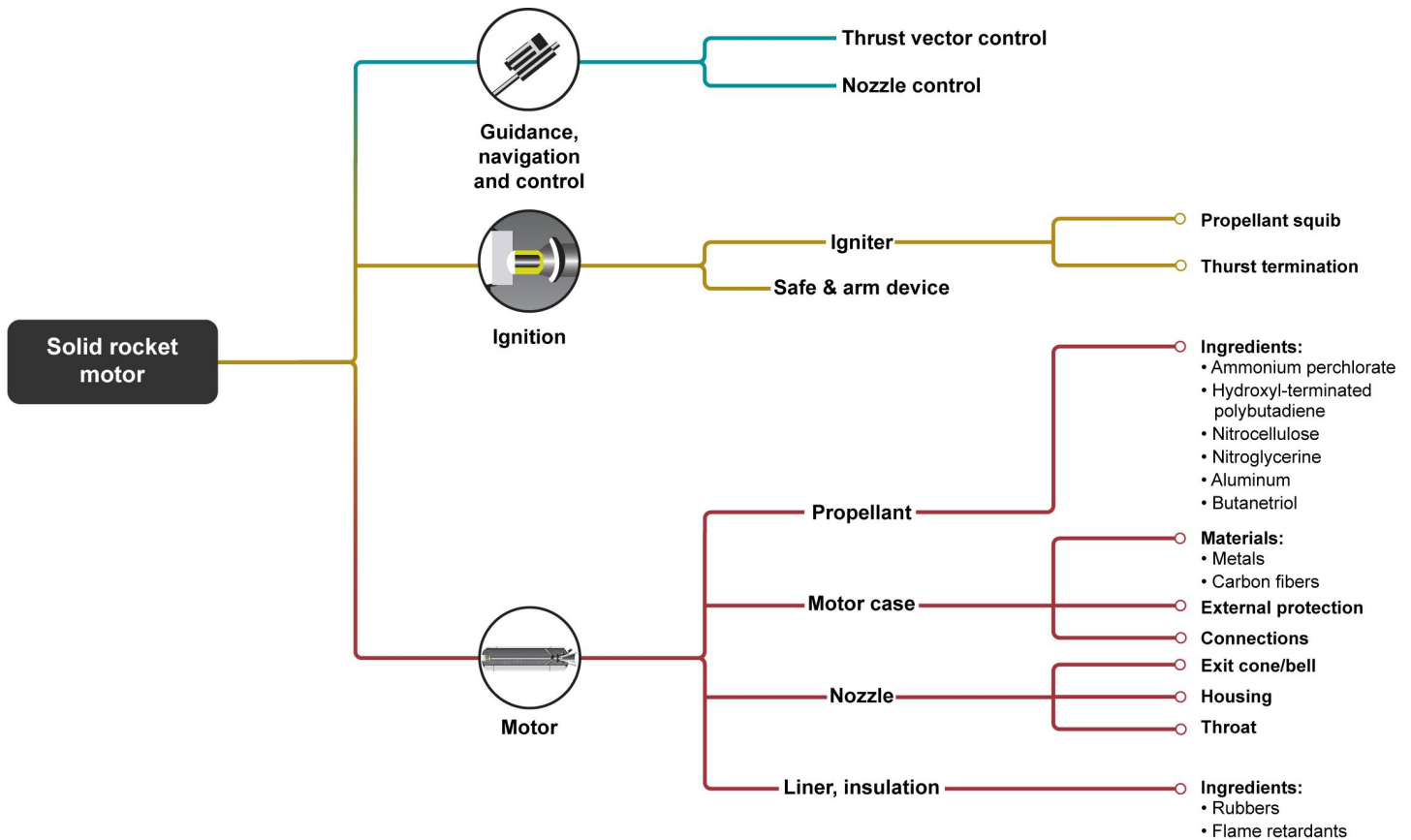

Source: GAO presentation of Department of Defense data. | GAO-18-45

Historically, the demand for SRMs was mostly driven by their use in solid rocket boosters for NASA space programs, such as the Space Shuttle program. DOD has reported that NASA’s retirement of the Space Shuttle program in 2011 had a negative impact on the SRM supply chain as it led to decreased demand for SRMs and the related raw materials and components. Similarly, we reported in August 2017 that the demand for solid rocket motor propellant had dropped by more than 75 percent, from 20 million pounds to 5 million pounds, since the end of the Space Shuttle program.<sup>5</sup> DOD has reported that these changing market conditions have resulted in excess capacity, where production demand is less than what is optimal to sustain the suppliers. Thus, excess capacity keeps SRM

<sup>5</sup>GAO, *Surplus Missile Motors: Sale Price Drives Potential Effects on DOD and Commercial Launch Providers*. [GAO-17-609](#) (Washington, D.C.: Aug. 16, 2017).

---

manufacturers from being cost competitive, which can jeopardize the viability of the manufacturers as well as their sub-tier suppliers.

---

## MIBP's Role in Identifying Industrial Base Risks

MIBP, which is part of the Under Secretary of Defense for Acquisition, Technology, and Logistics, is DOD's primary representative for issues affecting the defense industrial base. MIBP officials told us they conduct analyses of risks affecting defense supply chains and provide information to decision makers, including required annual reports to Congress. These reports cover a wide range of industrial capabilities for various types of systems, including missiles. For example, in fiscal year 2014, MIBP assessed the fragility and criticality risks facing missile production, by analyzing factors that would cause potential disruptions and would be difficult to replace if disrupted. This assessment identified solid rocket motors as one of the key risks.

While individual program offices and military departments are generally responsible for identifying risks within their own areas, MIBP officials stated that they coordinate and share information with relevant stakeholders for issues that affect multiple programs within or across the military departments. MIBP's coordination role, according to these officials, includes participating in or leading various coordinating bodies within DOD or other federal departments. For example, MIBP leads the Joint Industrial Base Working Group, which shares industrial base information across DOD agencies and military departments. In addition, MIBP co-leads the Critical Energetic Materials Working Group, a DOD-sponsored entity that focuses on ensuring the near- and long-term availability of energetic materials such as those used in SRMs, and suggesting risk mitigation strategies.<sup>6</sup>

MIBP officials told us that they also conduct an annual data collection effort among the military departments and other DOD agencies to identify defense industrial base areas of risk and to learn about ongoing issues across the industrial base. In addition, they noted that MIBP works closely with the Industrial Analysis Group within the Defense Contract Management Agency (DCMA), which conducts assessments to identify industrial base risks facing individual acquisition programs at various

---

<sup>6</sup>Energetic materials are substances capable of quickly releasing chemical energy, such as explosives, pyrotechnics, and propellants.

points in the program's life cycle and makes recommendations to program offices to help sustain a resilient and innovative defense industrial base. Additionally, DOD officials we spoke to said weapon program-specific risks are communicated through the military departments and to MIBP, which tracks them and determines their implications for the industrial base.

---

## Industry Trends Create Uncertainty for U.S. Solid Rocket Motor Suppliers

Over the last 20 years, the SRM industrial base has consolidated from six to two U.S. manufacturers—Aerojet Rocketdyne and Orbital ATK. Both manufacturers produce the small and large SRMs used in tactical and missile defense systems, and Orbital ATK also produces SRMs for strategic missiles. A senior MIBP official told us that current DOD needs require two SRM manufacturers, but there is not enough demand to keep three companies economically viable.

In DOD's industrial base reports to Congress, MIBP has reported that, while other industrial sectors are supported by commercial markets in addition to government needs, SRM manufacturers cater largely to the defense and space missions of the government and generally do not have a commercial base that can sustain production when the federal government's demand fluctuates. As a result, similar to the impact of NASA's Space Shuttle retirement on the SRM supplier base, trends or decisions made in a particular program area can have broader effects and potentially result in cost increases for other programs. For example, we found that a company that is supporting space launch has decided to source its SRMs from Orbital ATK instead of Aerojet Rocketdyne, which had previously produced the motors. This arrangement will take effect in 2019, and Aerojet Rocketdyne officials said that it is consolidating its facilities to reduce costs due to excess production capacity for these types of large SRMs. According to DOD, the resulting impact may affect costs in Aerojet Rocketdyne's remaining business units, including those that provide the smaller SRMs used for tactical missiles. DOD says that these costs would likely be passed on to the missile systems programs. Additionally, if Aerojet Rocketdyne decides to exit the large SRM market altogether, the lack of competition is likely to result in increased costs for other DOD programs that use large SRMs.

When there is limited demand, then a small supplier base can also be impacted by competition from foreign suppliers. Specifically, in the past several years, the two U.S. manufacturers have faced competition from a foreign supplier, Nammo Raufoss, and, more recently in 2017, a newly established U.S. corporation, Nammo Energetics Indian Head, Inc. (NEIH).<sup>7</sup> These two new entrants are both ultimately wholly owned by the same Norwegian parent company and, according to an MIBP official, have the potential to take away market share from the two longstanding domestic SRM manufacturers. Figure 3 shows the industry trends among SRM manufacturers.

**Figure 3: Industry Trends of Solid Rocket Motor Manufacturers since 1995**

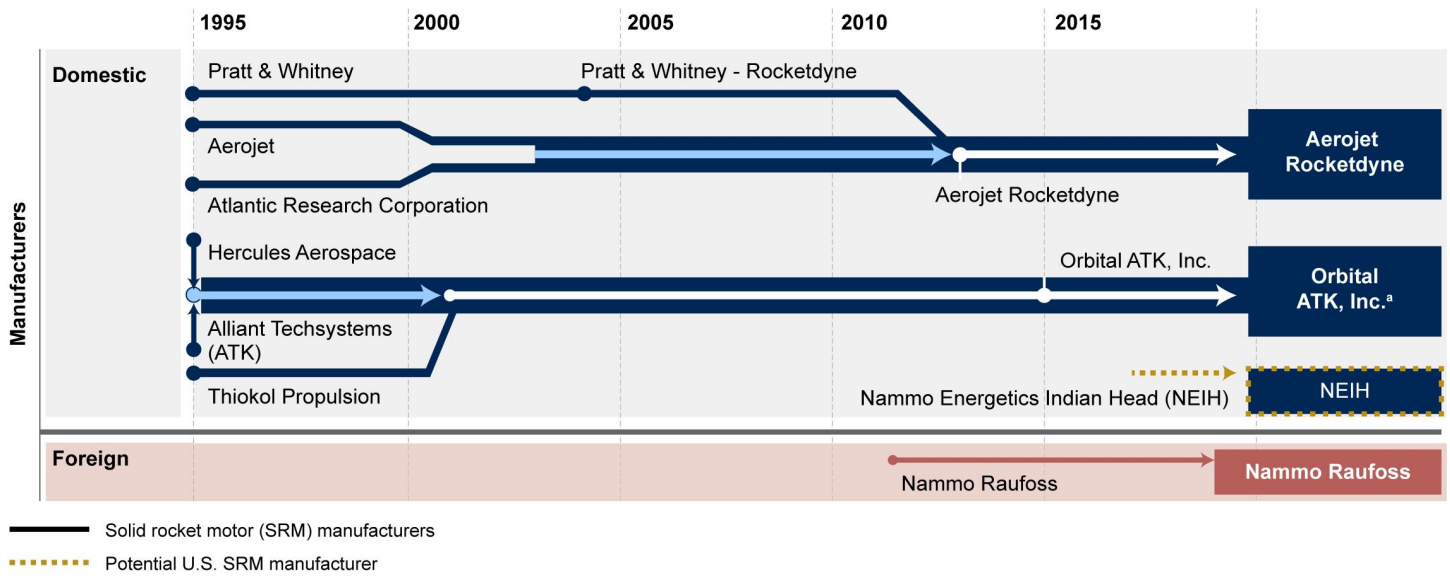

Source: GAO presentation of Department of Defense and industry information. | GAO-18-45

<sup>a</sup>In September 2017, Northrup Grumman announced plans to acquire Orbital ATK, Inc.

Nammo Raufoss, the foreign SRM manufacturer, began providing SRMs for the AMRAAM program in 2012, after the U.S. SRM manufacturer had encountered production challenges. According to an MIBP official, no U.S. SRM manufacturer, including the supplier at the time, was offered the opportunity to design a new SRM, which would have solved the

<sup>7</sup>Nammo Raufoss is a subsidiary of Nammo AS, a Norwegian company that is owned by the Norwegian government and a Finnish defense company. According to Naval Surface Warfare Center officials, Nammo Energetics Indian Head, Inc. (NEIH) is a wholly owned subsidiary of Nammo Inc., which in turn is a wholly owned subsidiary of Nammo AS.

production issues. Further, according to the MIBP official, the Norwegian government contributed funding to this effort. Additional funding was provided by the prime contractor—Raytheon—and the program offices, to develop, test, and produce the new SRM for AMRAAM.

Currently, Nammo Raufoss provides SRMs for two tactical missile programs used by DOD—Evolved Sea Sparrow Missile and AMRAAM.<sup>8</sup> The programs for which Nammo Raufoss provides SRMs accounted for approximately 4 percent of the tactical missiles procured by DOD in fiscal year 2017, a slight increase over the 3 percent share since it first provided SRMs for the AMRAAM missiles in fiscal year 2012. The remaining missile programs use SRMs produced by Aerojet Rocketdyne and Orbital ATK.

While the missile prime contractor found it viable to turn to a foreign source for the AMRAAM program, Congress and DOD have been concerned about the potential negative impacts the addition of a foreign supplier could have on a fragile domestic SRM industrial base. For example, the Senate Appropriations Committee recently noted concerns about reduced spending and the use of foreign suppliers.<sup>9</sup> Similarly, even though DOD recognizes that access to global markets provides the necessary competitive pressures to incentivize U.S. suppliers to remain competitive and control costs, it has also noted that there needs to be a commitment to investing in the U.S. SRM industrial base to develop and produce critical technologies for the next generation of weapon systems. Further, by law, DOD must limit specific conventional ammunition procurements to sources within the industrial base if it determines such limitation is necessary to maintain a facility, producer, manufacturer, or other supplier available for furnishing an essential item of ammunition or ammunition component in cases of national emergency or to achieve industrial mobilization.<sup>10</sup> According to MIBP officials, the current threat to the existing U.S. SRM manufacturer from a foreign supplier is not great enough to force it from the market. Therefore, it is difficult to restrict SRM procurements to the U.S. industrial base. Instead, an MIBP official told us

---

<sup>8</sup>Evolved Sea Sparrow Missile is an international cooperative effort, developed by the United States and member countries of the North Atlantic Treaty Organization.

<sup>9</sup>S. Rep. No. 113-211, at 99-100 (2014).

<sup>10</sup>Pub. L. No. 105-261, § 806 (1998). DOD Directive 5160.65 (dated March 8, 1995) specifies that conventional ammunition includes a variety of end products, including missiles.

they have raised concerns to DOD program offices and missile prime contractors about expanding the use of the Norwegian SRM supplier, Nammo Raufoss, as this potentially could have a negative impact on the near- or long-term survivability of U.S. manufacturers.

Moreover, our review found that the newly established NEIH as a U.S. SRM manufacturer also creates competition within the existing domestic supplier base and also raises uncertainty for Aerojet Rocketdyne and Orbital ATK.<sup>11</sup> Specifically, NEIH is in the early stages of establishing its production capabilities, which includes remodeling the manufacturing facility at Indian Head, over the next three years. Further, an MIBP official told us that MIBP plans to monitor the competitive landscape among the three companies, but as NEIH is a U.S. company, it is considered a part of the domestic industrial base and would not be subject to DOD restrictions on foreign suppliers. At this stage, it is too early to tell how, if at all, the newest competitor, whose product line is focused on small SRMs, will disrupt the business of the two long-standing U.S. SRM manufacturers that produce large and small SRMs.

---

## Single Source Suppliers Drive Material Availability Risks but Mitigation Actions Underway

During our review, we found that the decreased demand for SRMs has resulted in a loss of suppliers in the supply chain, increasing the risk that key components and materials are only available from single sources. Should such components and materials become unavailable, production delays could result. MIBP's industrial base reports to Congress and our discussions with industry representatives showed increased awareness of supply chain risks and steps taken to identify and mitigate risks before they affect SRM production, including coordination of efforts to address key chemicals needed for SRM propulsion.

---

<sup>11</sup>In January 2017, Nammo Energetics Indian Head (NEIH) entered into a public-private partnership agreement with Naval Surface Warfare Center, pursuant to 10 U.S.C. § 2474. Under the terms of this agreement, NEIH will manufacture warheads and rocket motors at the Naval Surface Warfare Center facility at Indian Head, Maryland.

---

---

## Single Source SRM Suppliers Increase Risk

As decreased demand for SRMs has contributed to the consolidation of manufacturers, a main concern for DOD and industry is the impact of similar reductions among the manufacturers' sub-tier suppliers. According to MIBP's reports to Congress, relying on a decreased number of sub-tier suppliers exacerbates the risk that needed SRM materials become unexpectedly unavailable and disrupt missile production. MIBP emphasizes that in the current lower-production environment, sub-tier suppliers who are primarily supporting defense and space missions rather than commercial businesses, must determine how to remain viable or decide to exit the SRM market. SRMs contain few commercial off-the-shelf components and a great number of defense-unique components, which leads to an extensive reliance on sole-source suppliers.

Further, DOD reported that the missiles that are powered by SRMs experience rapid production during times of conflict. While surge production can create additional business opportunities, it is greatly impacted by the availability of materials and components that comprise the SRM for the missile. Industry representatives told us that managing complex supply chains is a part of their business, but noted that there has been a great deal of consolidation among SRM suppliers in recent years. One SRM manufacturer estimated that the supply chain has dropped from approximately 5,000 sub-tier suppliers to about 1,000 suppliers over the last 20 years. As a result, manufacturers are heavily dependent on only one supplier for some of the raw materials and key components of the SRM. For example, manufacturers provided us with information showing that they rely on a single company for ignition components for most of the tactical missiles they produce.



#### Single Source Supplier Issues for the Advanced Medium-Range Air-to-Air Missile (AMRAAM)

A U.S. manufacturer experienced problems with the propellant mixture used in the AMRAAM solid rocket motor (SRM). The root cause was not discovered, but experts believe that variation in the raw material for a particular propellant ingredient resulted in the SRM functioning differently than intended. As a result, Raytheon, the prime missile contractor, stopped accepting the manufacturer's SRMs in 2010 and AMRAAM production was disrupted for about 2 years. At the time, Raytheon had been working to qualify a second SRM supplier. According to DOD, the qualification process was accelerated to speed up production of the missiles that were needed to support military operations. AMRAAM production resumed approximately 2 years after the SRM issues occurred.

Source: GAO analysis of information obtained from DOD and industry representatives | GAO-18-45

These dependencies increase as they move into the lower tiers of the supply chain. Components can be available from one source for either of the following two instances: (1) only one sole source is available for the material, component, or chemical and no other alternative exists; or (2) other suppliers exist, but only one single source supplier has been qualified or chosen to produce the item. Either situation poses a risk of disrupting the supply of SRMs and ultimately, the production of the missile. DOD officials noted that, even if other suppliers exist, it can be costly and time-consuming for them to be qualified as alternative sources. For example, in its assessments, DCMA has stated that energetic materials—which are used in SRM propellants—are among the most expensive components to requalify. As there are approximately 25 to 30 ingredients in the typical SRM's propellant, changes in any of the ingredients require that the propellant be retested for effectiveness.

Further, disruptions among single source suppliers can take place for other reasons besides leaving the market. Production changes, such as altering manufacturing processes or even relocating production facilities, can affect the material or component produced in unexpected ways. In addition, there has been a long-standing concern that SRM manufacturers are dependent on a single source supplier for an SRM propellant ingredient—ammonium perchlorate—as only one U.S. company is certified to provide this ingredient. The House version of the Fiscal Year 2018 National Defense Authorization Act calls for DOD to study the future costs and availability of ammonium perchlorate. MIBP officials told us they have conducted extensive analysis of the issues for this critical component, including two studies conducted in 2016.

### Industry's Efforts to Manage Its Supply Chain

Industry representatives from missile prime contractors and SRM manufacturers we spoke with said that managing their supply chain to ensure the availability of needed materials is a primary concern. Prime contractor representatives said that SRM subcontractors are generally expected to manage their suppliers and ensure that they suppliers can meet their contract requirements. However, the prime contractors said they are particularly involved when the risks relate to material availability. While losing a supplier is always a risk, they try to mitigate this through increased awareness of their supply chains and taking quick actions when risks are identified.

- To increase awareness, prime contractor representatives said they consider potential availability issues before contracts are awarded and include requirements that they be notified of these issues in their subcontracts, which the SRM manufacturers apply to their subcontract suppliers, in order to minimize surprises. One SRM manufacturer confirmed that it includes subcontract requirements for its own sub-tier suppliers to report any changes in the product, materials, or production location as soon as the change is known.
- In addition, both of the U.S. SRM manufacturers noted that they have staff dedicated to monitoring potential issues with supply chain availability. In one case, a manufacturer conducted a business continuity study that analyzed suppliers' business plans for the next 5 years to identify potential problems.
- After issues—such as a financially fragile supplier—are identified, representatives said the key factor is the amount of time they have to mitigate the issue. In this respect, the U.S. SRM manufacturers we spoke with said their processes have improved in recent years and they receive more advanced notice when suppliers plan to exit the market, allowing them to take steps such as stockpiling supplies or making last buys while additional suppliers are identified. Taking such steps also allows time to more fully assess and take necessary steps—including qualifying a new supplier, if needed.

---

## DOD Efforts to Respond to Supply Chain Risks

MIBP officials told us that they coordinate regularly with industry and the affected DOD program offices to be informed of potential issues in the supply chains, but noted that it can be challenging to be aware of SRM suppliers beyond the initial tiers. However, the officials said that through their coordination efforts—which include participating in multiple working groups with the military departments and DOD components, as well as NASA and industry—they are aware of the SRM sub-tier suppliers that are at the greatest risk. For example, MIBP co-leads the Critical Energetic Materials Working Group to track availability issues with the chemicals that DOD relies on, including SRM propellant ingredients. Officials said that MIBP also works closely with DCMA, which conducts industrial base assessments that provide additional insights into contractors' supply chains. Further, officials said that MIBP is in the early stages of developing a business analytics tool to help them better understand the interdependencies in the sub-tier supplier base. Their hope is to be able to proactively identify risks, rather than wait for program offices or DCMA to elevate concerns to MIBP.

DOD officials and industry representatives identified cases in which actions were taken when essential materials—typically chemicals—were at risk of becoming unavailable. For example, MIBP coordinated with other DOD stakeholders and industry to mitigate risks in the cases summarized in table 1.

**Table 1: Department of Defense (DOD) and Industry Actions to Address Certain Single Source Supplier Risks**

| SRM component | Chemical ingredient               | DOD and Industry Actions   |
|---------------|-----------------------------------|--|
| Propellant    | Dimeryl-di-isocyanate (DDI)       | The only U.S. supplier of this critical propellant ingredient used in many DOD missile systems, including Advanced Medium Range Air-to-Air Missile (AMRAAM), AIM-9X, and Guided Multiple Launch Rocket System, informed the solid rocket motor (SRM) manufacturers that it planned to discontinue production, which would have left DOD without a qualified source for these programs. The Manufacturing and Industrial Base Policy (MIBP) office coordinated with the military departments to identify usage data and affected programs to demonstrate to the supplier the importance of this item to DOD. The SRM manufacturer noted that the supplier reversed its decision to discontinue production after becoming aware of the chemical's importance to DOD. |
| Propellant    | Hydroxyl-terminated polybutadiene | A polymer used in many DOD missile systems, which is currently produced in the United States by a French company, has had a number of deficiencies in quality and reproducibility. This has resulted in the material being unusable in certain missile systems. MIBP and the Army have coordinated funding efforts to establish and qualify a second source for this material. Funding is used to manufacture more production scale batches for reliability and repeatability testing, and to test the new material in a rocket propellant formulation.  |
| Propellant    | Butanetriol                       | From 2008 to 2014, DOD was dependent on a restricted foreign source of this chemical used in the production of several missiles. Obtaining this material from a foreign source required a waiver from the Secretary of the Army. MIBP, in coordination with the Army, funded efforts to stand up a domestic source of the material in 2014. However, this new domestic source remains the single qualified source of the material.   |
| Insulation    | Dechlorane Plus 25                | Nearly all DOD missile systems use this chemical in their SRM insulation. There is no domestic supplier for this material; furthermore, another chemical needed to produce this material is no longer in production. DOD and industry are working to find a replacement material. MIBP has established a working group to coordinate information sharing and mitigation activities across DOD and to leverage efforts to arrive at a more efficient and cost effective solution.   |

Source: GAO analysis of DOD and industry information. | GAO-18-45

Additionally, an official said that MIBP is conducting a munitions industrial base resiliency study in 2017 that addresses, among other issues, how DOD plans for risks in the missile sector, particularly those related to the loss of qualified suppliers, including for SRMs.

In September 2017, we reported that DOD program offices have limited information from contractors that would help them to identify and proactively manage risks stemming from a single source of supply for

---

missile systems, among other items.<sup>12</sup> We recommended that DOD develop a mechanism to ensure that program offices, such as those for missile programs, obtain information from contractors on single sources of supply risks. DOD concurred with this recommendation and indicated that modifications to current contractual regulations and policy would be beneficial. In light of DOD's planned actions in response to our previous recommendation, we are not making any additional recommendations at this time.

---

## Manufacturing Engineers' Solid Rocket Motor Design Skills Declining but Workforce Project Initiated

MIBP's annual industrial capabilities reports to Congress have consistently stated that the limited number of new missile development programs inhibits DOD's ability to provide opportunities that maintain the workforce capabilities SRM manufacturers need to meet current and future national security objectives. These capabilities include engineering skills related to SRM concept designs, system development, and production, which are critical to meeting potential requirements for new SRM designs. With few new-start missile programs being initiated and decades-old programs having reached a steady state of design, SRM engineers are not typically engaged at the early stages of development and newer engineers have not fielded new SRM designs, thus creating a skills gap. According to reports from DOD, the lack of new programs for missiles has also limited opportunities to recruit and train the next generation of SRM scientists and engineers. The SRM manufacturers we spoke with also acknowledged experiencing attrition among workers with the requisite experience, as design experts are at or near eligibility for retirement. Industry representatives noted that engineers and chemists do not typically go to school to become SRM engineers, but must be trained by the SRM manufacturers. In a report to Congress, MIBP stated that one SRM manufacturer estimated that it can take up to 5 years to fully train SRM engineers or production workers.

Key to this issue is the limited number of new missile programs or updates requiring new SRM designs, which would provide the workforce

---

<sup>12</sup>GAO, *Defense Supply Chain: DOD Needs Complete Information on Single Sources of Supply to Proactively Manage the Risks*. [GAO-17-768](#) (Washington, D.C.: Sept. 28, 2017).

with development opportunities that DOD and industry find to be critical. Current research and development efforts are generally limited to updates or modifications for legacy missile programs, rather than for new missile programs. For example, the Joint Air-to-Ground Missile, a tactical missile program that officials said has started and stopped development several times since the late 1990s, had planned to incorporate a new SRM design. However, due to budget limitations and affordability concerns related to the SRM, the program opted to use a legacy SRM from the Hellfire missile, which has been in production since 1982. While the legacy SRM requires some modifications to change the casing material from steel to composite materials that are stable enough to withstand fire, mechanical shocks, and shrapnel, yet still burn correctly to propel the warhead and destroy the intended target, it does not involve the same level of skill as is needed to design new SRMs. Similarly, a DOD official said the AIM-9X program proposed designing a new SRM, but this plan was later abandoned due to concerns about the overall program costs. There are currently only two missile programs—Army’s Long Range Precision Fire missile and the Navy’s Advanced Anti-Radiation Guided Missile Extended Range—planning to use new solid rocket motor designs. Although these programs present opportunities for industry to develop SRM design skills, MIBP does not believe it will close the current skills gap. Further, MIBP officials said they have raised concerns that the use of foreign SRM suppliers results in fewer opportunities for domestic SRM manufacturers such as exercising their design skills. For example, MIBP noted that domestic engineers did not have the chance to design the new SRM used by AMRAAM.

In its reports to Congress, MIBP has stated that the loss of design capabilities could result in costly delays and unanticipated expenses and impair DOD’s readiness to support existing systems and field new capabilities. One of the elements that heighten SRM criticality for missile systems is the long lead time for restarting production in the event of stoppage. Specifically, one MIBP report stated that SRM manufacturers estimated that it can take from 3 to 5 years to fully restart if there is some ongoing production, and up to 8 years if production has completely ceased. In addition, according to MIBP, restarting production processes would incur costs, including those associated with retraining engineers. MIBP also indicated that the loss of SRM capabilities could delay future development of missile programs by 5 to 10 years.

MIBP has an effort underway intended to address these diminishing design skills. According to MIBP officials, in 2016 they awarded a 4-year risk mitigation project that will provide approximately \$14 million to Orbital

ATK and Aerojet Rocketdyne during the course of the project. The purposes of the project are to provide opportunities for the SRM manufacturers to develop new SRM design skills for less experienced engineers and mature advanced technologies. The engineers will incorporate technology into a new SRM as designed by each company. According to an official, MIBP provided general guidelines for the resulting SRM, but purposely did not provide strict specifications in an effort to allow engineers to identify their own solutions for a new motor design.

---

## Agency Comments

We are not making recommendations in this report. We provided a draft of this report to DOD for comment. DOD reviewed the draft and offered technical comments, which we incorporated as appropriate.

We are sending copies of this report to the appropriate congressional committees, the Secretary of Defense, and other interested parties. In addition, the report is available at no charge on the GAO website at <http://www.gao.gov>.

If you or your staff have any questions about this report, please contact me at (202) 512-4841 or [makm@gao.gov](mailto:makm@gao.gov). Contact points for our Offices of Congressional Relations and Public Affairs may be found on the last page of this report. GAO staff who made key contributions to this report are listed in the appendix.

Sincerely yours,



Marie A. Mak  
Director, Acquisition and Sourcing Management

---

## Appendix: GAO Contact and Staff Acknowledgments

---

### GAO Contact

Marie A. Mak, (202) 512-4841 or [makm@gao.gov](mailto:makm@gao.gov).

---

### Staff Acknowledgments

In addition to the contact named above, Candice Wright (Assistant Director), Alyssia Borsella, Jennifer Dougherty, Leigh Ann Haydon, Emily Bond, Lorraine Ettaro, Kurt Gurka, and Roxanna Sun made key contributions to this report.

---

---

## GAO's Mission

The Government Accountability Office, the audit, evaluation, and investigative arm of Congress, exists to support Congress in meeting its constitutional responsibilities and to help improve the performance and accountability of the federal government for the American people. GAO examines the use of public funds; evaluates federal programs and policies; and provides analyses, recommendations, and other assistance to help Congress make informed oversight, policy, and funding decisions. GAO's commitment to good government is reflected in its core values of accountability, integrity, and reliability.

---

## Obtaining Copies of GAO Reports and Testimony

The fastest and easiest way to obtain copies of GAO documents at no cost is through GAO's website (<http://www.gao.gov>). Each weekday afternoon, GAO posts on its website newly released reports, testimony, and correspondence. To have GAO e-mail you a list of newly posted products, go to <http://www.gao.gov> and select "E-mail Updates."

---

## Order by Phone

The price of each GAO publication reflects GAO's actual cost of production and distribution and depends on the number of pages in the publication and whether the publication is printed in color or black and white. Pricing and ordering information is posted on GAO's website, <http://www.gao.gov/ordering.htm>.

Place orders by calling (202) 512-6000, toll free (866) 801-7077, or TDD (202) 512-2537.

Orders may be paid for using American Express, Discover Card, MasterCard, Visa, check, or money order. Call for additional information.

---

## Connect with GAO

Connect with GAO on [Facebook](#), [Flickr](#), [LinkedIn](#), [Twitter](#), and [YouTube](#).  
Subscribe to our [RSS Feeds](#) or [E-mail Updates](#). Listen to our [Podcasts](#).  
Visit GAO on the web at [www.gao.gov](http://www.gao.gov) and read [The Watchblog](#).

---

## To Report Fraud, Waste, and Abuse in Federal Programs

Contact:



---

Website: <http://www.gao.gov/fraudnet/fraudnet.htm>  
E-mail: [fraudnet@gao.gov](mailto:fraudnet@gao.gov)  
Automated answering system: (800) 424-5454 or (202) 512-7470

---

## Congressional Relations

Katherine Siggerud, Managing Director, [siggerudk@gao.gov](mailto:siggerudk@gao.gov), (202) 512-4400,  
U.S. Government Accountability Office, 441 G Street NW, Room 7125,  
Washington, DC 20548

---

## Public Affairs

Chuck Young, Managing Director, [youngc1@gao.gov](mailto:youngc1@gao.gov), (202) 512-4800  
U.S. Government Accountability Office, 441 G Street NW, Room 7149  
Washington, DC 20548

---

## Strategic Planning and External Liaison

James-Christian Blockwood, Managing Director, [spel@gao.gov](mailto:spel@gao.gov), (202) 512-4707  
U.S. Government Accountability Office, 441 G Street NW, Room 7814,  
Washington, DC 20548